

Installation Instructions

1. Mill flat down to .932 dim. Do not go past the .87 Ref.
2. Set machine X zero at point "A"
3. Pickup Z zero on machined flat with 65 degree cutter.
4. Move to .771 dim. and .125 depth and make initial dovetail cut.
5. Make additional cuts to widen dovetail to fit.
6. Remove sharp corner as shown, and file a 5 degree +/- angle to help fit.

Notes: The .932 dimension works well with Government models using a .180 front sight, but may be varied.

Commander length slides should be set at .010 more or .942.

Different barrel fits will also effect point of impact. A long link will make the gun shoot lower. This may be changed by using a different height front sight.

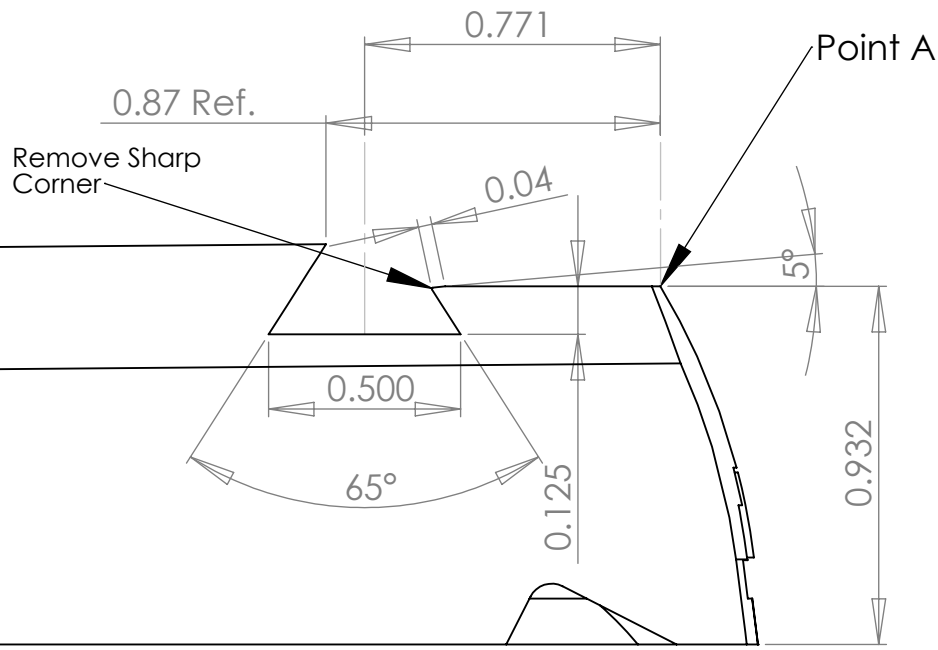

PROPRIETARY AND CONFIDENTIAL

THE INFORMATION CONTAINED IN THIS DRAWING IS THE SOLE PROPERTY OF Ed Brown Products, Inc.

ANY REPRODUCTION IN PART OR AS A WHOLE WITHOUT THE WRITTEN PERMISSION OF Ed Brown Products, Inc. IS PROHIBITED.

		UNLESS OTHERWISE SPECIFIED:	NAME	DATE				
		DIMENSIONS ARE IN INCHES	DRAWN	EB				
		TOLERANCES:	CHECKED					
		FRACTIONAL ±	ENG APPR.					
		ANGULAR: MACH ± BEND ±	MFG APPR.					
		TWO PLACE DECIMAL ±	Q.A.					
		THREE PLACE DECIMAL ±	COMMENTS:					
		INTERPRET GEOMETRIC TOLERANCING PER:			Ed Brown Products, Inc. P.O. Box 492 43825 Muldrow Trail Perry, MO 63462 573-565-3261			
		MATERIAL					SIZE	DWG. NO.
		FINISH					A	EB-Rear-Sight
NEXT ASSY	USED ON	APPLICATION	DO NOT SCALE DRAWING		SCALE: 1:2	SHEET 1 OF 1		